

BouMatic Air-Star Vacuum Pumps

No oil technology means a cleaner, more environment-friendly vacuum pump

■ Economical

Air-Star vacuum pumps eliminate lubricant expenses from your books

■ Long-life Pump

Gears and bearings are splash oil-lubricated ; figure-eight impellers never touch each other

■ Non-polluting

No used oil

■ Reduced Maintenance

Air-Star pumps are produced with high-quality components (the life of the bearings exceeds 100,000 hours of operation)

■ High Performance

High and stable vacuum level per kW

■ Reliability

Manufactured for long life

Every Air-Star pump is bench-tested to make sure it meets the tough BouMatic specs, to make sure your Air-Star pump works as it should.

Air-Star vacuum pumps are custom-manufactured to exacting BouMatic specifications and tolerances, to provide maximum capacity for your investment dollar.

- Custom-built to BouMatic high performance specifications
- Impellers are machined from cast iron to an exact profile and are permanently fastened to steel shafts
- Vertical stand features heavy-duty, all welded construction
- Impellers are dynamically balanced to operate without vibration in any assembled position
- Pump is set waist-high for ease of maintenance
- Cast iron headplate interior surfaces are ground to precise operating tolerances
- Bearing fits are machined into headplates to ensure exact bearing positioning
- Cast iron-machined impeller cases are heavily ribbed to prevent distortion; inlet and discharge ports are integral features of the cylinder
- Anti-friction bearings are used exclusively; smaller size pumps are fitted with single-row ball bearings, larger size pumps have double-row bearings and spherical roller bearings for overhung load capacity
- Timing gears are made from hardened alloy steel
- Open design for maximum cooling
- Oil level sight glass
- Timing gears and gear-end bearings are splash oil lubricated in an oil-tight housing
- Drive-end bearings are grease lubricated through fittings
- Lip-type seals prevent oil and grease from entering the impeller chamber



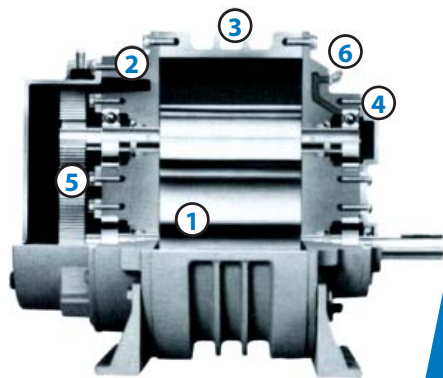

1 . Impellers are machined from cast iron blocks and are balanced and fastened directly on the steel shaft, so there will not be any vibrations.

2 . The headplates are made from cast iron and are maximum precision-ground. The fit of the bearing is machined directly into the headplate.

3 . The pump casing, too, is made from cast iron. Additionally reinforced, it will sustain everything without distortions. Grease nipples are an integral part of the pump casing.

4 . All ball bearings are anti-friction bearings; large pump models are constructed with double-row bearings, so they will support even the highest loads, or with roller bearings to compensate the overhung load.

5 . Gears are made from hardened steel; large ones are set on removable hubs, while smaller ones are set directly onto the shaft.

6 . Lubrication: gears are continuously splash oil-lubricated in an oil-tight housing, and every bearing is fitted with its own grease nipple.



Vacuum is supplied through 2 impellers turning in opposite directions

Air-Star vacuum groups

1. may be fitted with a second silencer, to lower the noise level even more.
2. have easily accessible gears.
3. have easily accessible bearings: the oil (assuming synthetic oil is used) has to be replaced every 4500 hours.
4. have a full guard to protect the pulleys and belts.
5. The motor support panel allows optimum belt tension setting.
6. The panel legs are individually adjustable for easier horizontal levelling of the group.

Model	Air Flow at 50kPa, in l/min	Pump Speed, in rpm	Motor Power, in kW
BVP 100	1200	3090	4
BVP 140	1050	2015	4
BVP 140+	1800	2800	5.5
BVP 200	1550	1430	5.5
BVP 200+	2600	1930	7.5
BVP 400	3900	1990	11
BVP 400+	5300	2390	15

Your dealer:

